

202T Tube Diameter - 20mm

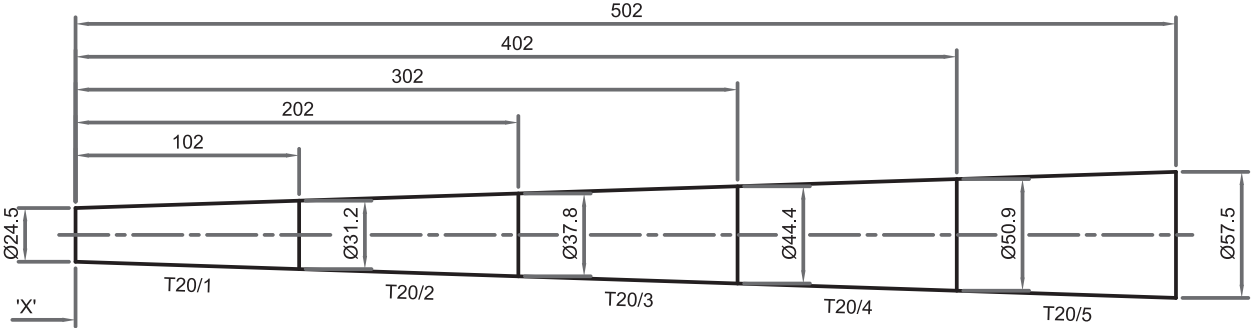
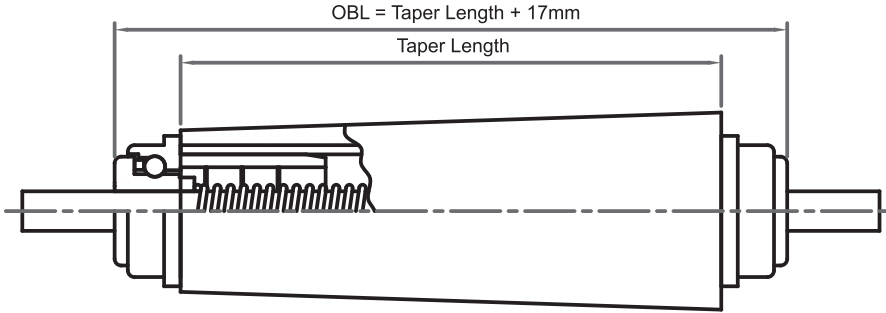

'X' = Inner Radius 373mm

Tapered Elements For Ø20 Tube

Tube		Bearings		Bearings		Shaft Materials	
Materials	20 x 1.6 - Aluminium	Materials	Black polypropylene	Materials	Thermoplastic race	Materials	Standard - S/S
	20 x 1.5 - Plastic				S/S balls		Option - Mild steel
						Size	Ø8mm
						Type	Standard - SP
							Options - DL, F, L, MT

- Load Rating kg (Minimum applies).

Roller Length (mm)	Tube Material		Shaft Ø8mm
	Dynopipe	Aluminium	
119	9	9	9
219	5	9	9
319	2	9	9
419	1	9	2
519		8	1

\* Shaded sizes not recommended

- Max. speed 9m/min.
- Max. static load 4.5kg.
- For central point load, reduce load rating by 1/3.
- Common uses;
  - Small packages around corners.
  - Matches well with roller type 251 / 252.