



A to B, seamlessly.



Multiroll Catalogue '17



It's how businesses get along

---

At Dyno we make the world of  
business go round.

Up and down.

And side to side.

Our conveyors make moving meat,  
veges, fruit, packages, gravel, and even luge sleds simple and  
efficient.

We can customise to meet your needs  
and all our designs are proprietary.

It all sounds new and high-tech, and it is.  
But in reality we're an inter-generational  
Kiwi company which has been designing and building conveyors  
for over two decades now.

All that experience, and our knowledge  
of the industries we work with,  
is part of a total approach that includes supplying parts, and  
maintenance by trained engineers.



**DYNO Conveyors warranties equipment supplied free from defective materials and workmanship for a period of 5 years, subject to satisfactory care and maintenance and being used according to original specifications.**

# CONTENT

---

Ball Transfers ..... 4

Multi Directional Rollers ..... 5

Dynofloat ..... 6

Glass Castors ..... 6

**BT 253 - B**

- Load capacity 50kg.
- Zinc plated pressing.
- Hardened balls.
- Stainless steel pressing and balls BT253SS-B

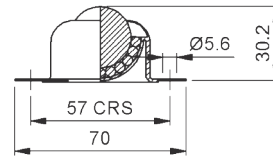
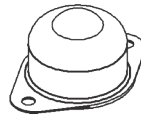

**BT 253 - B Nylon**

- Nylon Ball
- Load Capacity: 25kg Ball up, 10kg Ball down
- Non-Marking Product, suitable for glass

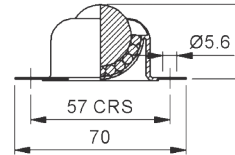
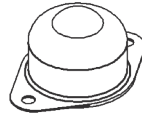

**BT 253 - P**

- Load capacity 50kg.
- Zinc plated pressing.
- Hardened balls.

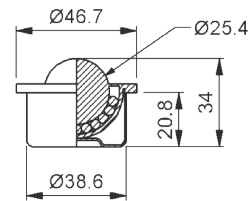
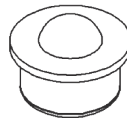

**BT 253 - MT**

- Load capacity 50kg.
- Zinc plated pressing.
- Hardened balls.

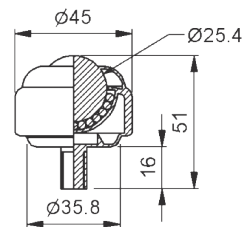
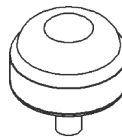

**BT 253 - F**

- Load capacity 60kg.
- Zinc plated pressing.
- Hardened balls.
- Stainless steel pressing and balls BT253SS-F

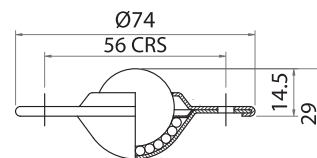
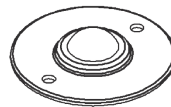

**BT 323 - B**

- Load capacity 100kg.
- Zinc plated pressing.
- Hardened balls.

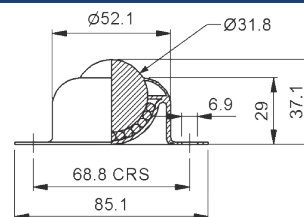
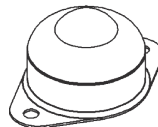

**BT 303 - P**

- Load capacity 150kg.
- Zinc plated pressing.
- Hardened balls.

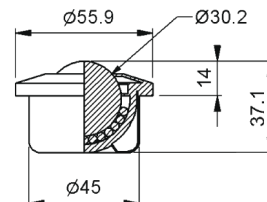
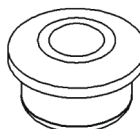

**BT 304 - P**

- Load capacity 145kg.
- Zinc plated housing.
- Stainless steel balls.

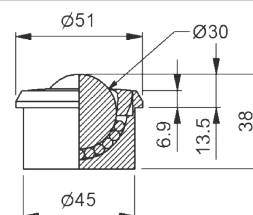
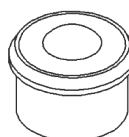

\*Other options available on request

# MULTI DIRECTIONAL ROLLERS

---

## MTR 50 Multi Directional Roller

- Load capacity 5kg each.
- Black acetal core.
- Grey acetal rollers.
- S/S axles.
- Connecting piece to make double rollers (recommended).

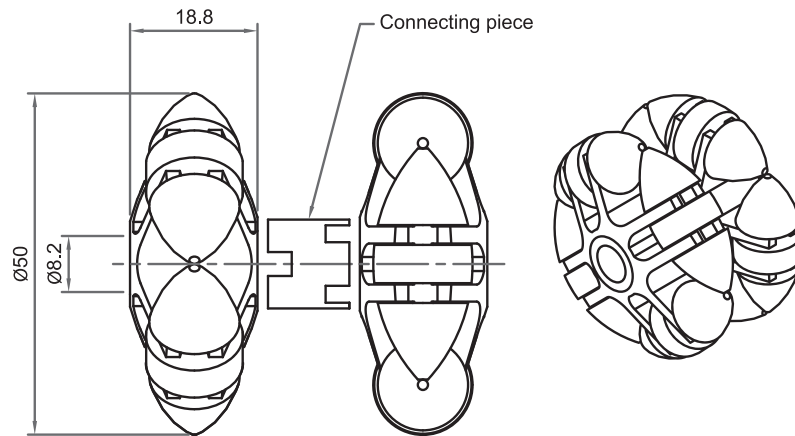

---

## MTR 80 Multi Directional Roller

- Load capacity 20kg each.
- Black acetal core.
- Grey acetal rollers.
- S/S axles.
- Connecting piece to make double rollers (recommended).

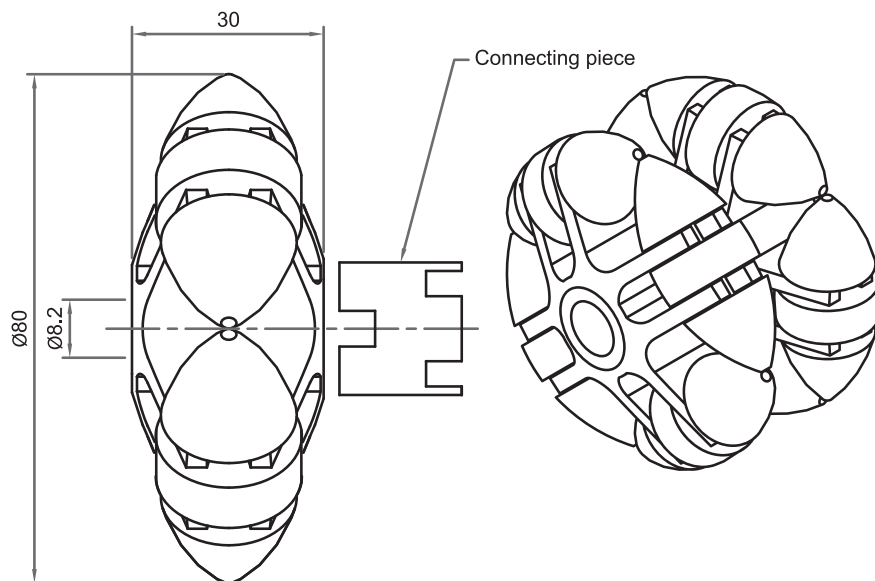

Ball Castors allow smooth, safe conveying and directional changes for sheet materials whilst protecting delicate or polished surfaces

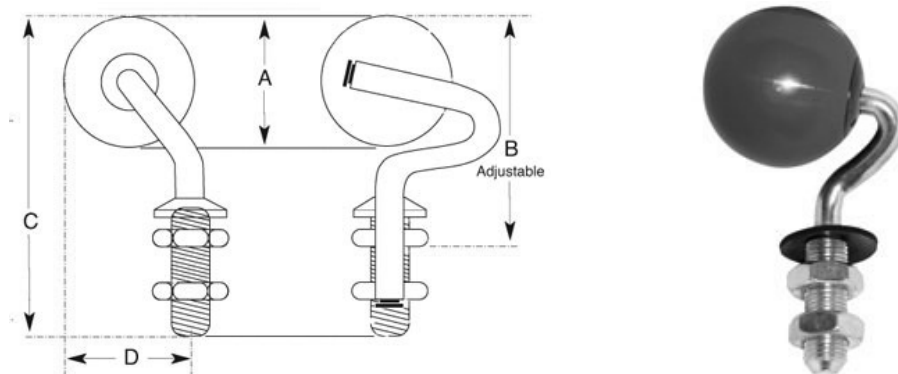

- Strong and practical, Dyno-floats perform in wet, dry, dusty and arduous conditions for easy handling of sheet materials such as glass and wood.
- Dynofloat ball castors are normally supplied with a 50% mix of 'left' and 'right' swivel trail which we recommend are fitted in a regular pattern to minimize bias for a neutral conveying surface.
- Optional Polyurethane ball material has a hardness of 90 shore (A scale) providing a high resistance to 'tearing' & wear whilst retaining the non-marking properties of this long-lasting superior material

50mm	A	B (min-max)	C	D	Thread	Load Rating
Dyno 50-100P Polyurethane	50	69-91	107	53.5	M14	22kg
ACR50 Rubber	50	73-95	106	58	M14	20kg

35mm	A	B (min-max)	C	D	Thread	Load Rating
Dyno 35-75R Black Rubber	35	54-71	87	37.5	M14	18kg

## GLASS CASTOR

- Adjustable height
- Drilled hole fixing

Code: 3001-14-50PB (Black Phenolic load balls)

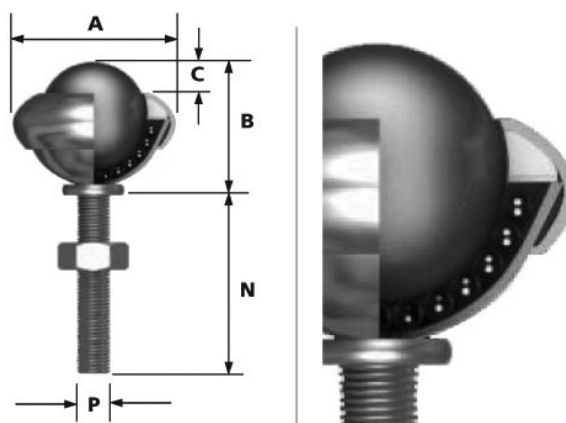

Ref.No	Ball Size (mm)	Max Torque on Nut (Nm)	Weight (kgs)	Dimensions (mm)						Type 14	
				A	B	C	D	N	P	Load Up	Load Down
3001	19	15	0.060	32.1	24.6	4.7	-	50	M8	20	10

- Other options available, also used for Glass – call us on 0800 144 044



A to B, seamlessly.



Auckland 09 320 5535  
Canterbury 03 307 0044  
Southland 03 216 1440

Freephone 0800 144 044  
Email [sales@dyno.co.nz](mailto:sales@dyno.co.nz)  
[www.dyno.co.nz](http://www.dyno.co.nz)



It's how businesses get along